

ON THE ESTIMATION OF THE DEFORMABILITY

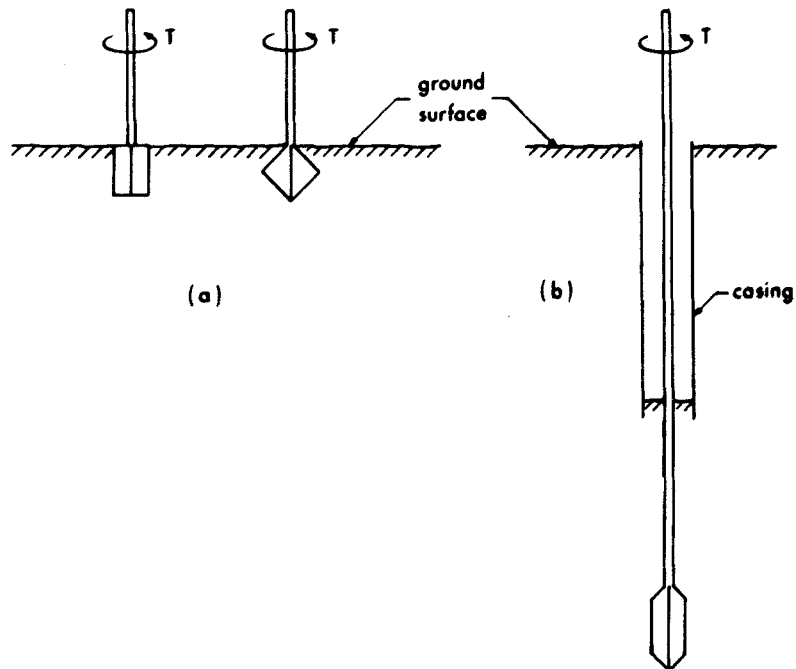

Figure 1. Installation procedures. (a) Shear vane located near the ground surface, (b) Shear van located at a large depth

the other hand, the torque-twist relationship is accurately recorded throughout the test then it
is reasonable to assume whether the initial portion of such a torque-twist curve is in any

taneous to induce a state of deformation or stress in the soil medium which will minimize the

where D^2 is Stokes' differential operator, which has the form

$$D^2 = h^2 h_3 \left\{ \frac{\partial^2}{\partial \alpha^2} + \frac{\partial^2}{\partial \beta^2} - \coth \alpha \frac{\partial}{\partial \alpha} - \cot \beta \frac{\partial}{\partial \beta} \right\} \quad (8)$$

The analysis of the elasticity problem in rotational symmetry is thus reduced to the deter-

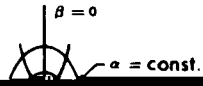

Using the above equations, the torque-twist relationship (15) can be reduced to the form

$$T = \frac{32\pi a_p^3 G \omega [1 - \lambda^2]^{3/2} \lambda^2}{L} \quad (17)$$

undrained shear strength (c_u) is fully mobilized along the entire boundary $\alpha = \alpha_0$, i.e.,

$$T_y = \int_0^\pi \int_0^{2\pi} \left[c_u c_p \frac{\sinh \alpha \sin \beta}{hh_3} \right]_{\alpha=\alpha_0} d\gamma d\beta \quad (21)$$

An evaluation of the above integral leads to

$$T_y = \frac{4\pi a_p^3 c_u \lambda^2}{3} \left[\left(\frac{2-\lambda^2}{1-\lambda^2} \right) E\left(\frac{\pi}{2}, \sqrt{1-\lambda^2}\right) - \frac{\lambda^2}{(1-\lambda^2)} F\left(\frac{\pi}{2}, \sqrt{1-\lambda^2}\right) \right] \quad (22)$$

where $E(\pi/2, \zeta)$ and $F(\pi/2, \zeta)$ are complete elliptic integrals of the first and second kind respectively, defined by

$$\begin{aligned} E\left(\frac{\pi}{2}, \zeta\right) &= \int_0^{\pi/2} \sqrt{1-\zeta^2 \sin^2 \theta} d\theta \\ F\left(\frac{\pi}{2}, \zeta\right) &= \int_0^{\pi/2} \frac{d\theta}{\sqrt{1-\zeta^2 \sin^2 \theta}} \end{aligned} \quad (23)$$

Tabulated numerical values for these functions are given by Byrd and Friedman.²⁵

Circular vane problem

The ultimate torque for the deep circular vane occurs as a limiting case of (22) as $\lambda \rightarrow 1$. By

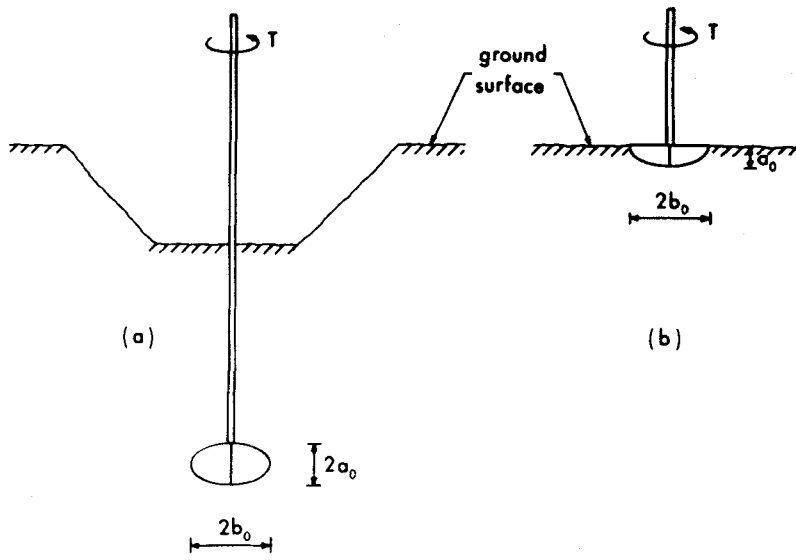

Figure 3. The oblate shear vane problem. (a) Shear vane located at a large depth. (b) Shear vane located at the ground surface.

ULTIMATE TORQUE MOBILIZED BY THE OBLATE VANE

Again, expressions for the ultimate torque mobilized by an oblate vane can be developed using the techniques outlined earlier. It is assumed that the undrained shear strength of the saturated

CONCLUSIONS

The shear vane tests are extensively used in the determination of the undrained shear strength characteristics of cohesive soils tested under both laboratory and field conditions. This paper

5. L. Cadling and S. Odenstad, 'The vane borer: An apparatus for determining the shear strength of clay soils directly